

- High integration and low failure rate
- Type approval with DNV (MED) and CCS



- Designed to use for emergency purpose on the life raft.
- Compared to RADAR-SART, AIS-SART has advantages in some aspects, such as farther-reach transmission and less effect from sea conditions. With more and more vessels to be fitted with AIS, AIS-SART will become more effective and useful in SAR operations.
- Designed to transmit a serial of messages on two AIS channels periodically. With unique and special MMSI pre-configured, alerts from AIS-SART can be easily recognized and read, which is sent both in position report and safety message.
- Adopts low consumption design to ensure the product to continuously operate more than 96 hours.



SPECIFICATIONS

● TECHNICAL SPECIFICATIONS

- TX Channel: AIS 1, AIS 2
- FREQ Tolerance: ≤ 0.5 kHz
- Communication Range: ≥ 5 nm
- Operating Hours: ≥ 96 hours
- GNSS Fixing Time: ≤ 1 minute

● BATTERY REQUIREMENTS (NBT100)

- Operating hours: 96 hours (in activation mode)
- Storage Life: Max 5 years on board
(plus one year of shelf time)

● GNSS Receiver

- Type: Built-in GNSS antenna
- System Supported: GPS, Glonass, BDS

● SIZE & WEIGHT

- Size: 95 (D) \times 377 (L) mm
- Weight: 900 g

● WORKING ENVIRONMENTS

- Operation Temp: $-20^{\circ}\text{C} \sim +55^{\circ}\text{C}$
- Storage Temp: $-40^{\circ}\text{C} \sim +70^{\circ}\text{C}$
- Floating Type: Floatable
- Watertight: At a depth of 10m for at least 5 min

EQUIPMENT LIST

● STANDARD

- Transponder NAS-1000 1 pc
- Mounting Bracket 1 pc
- Tele-Pole (1.5 m) 1 pc
- Accessories 1 set



SIZE DIMENSION

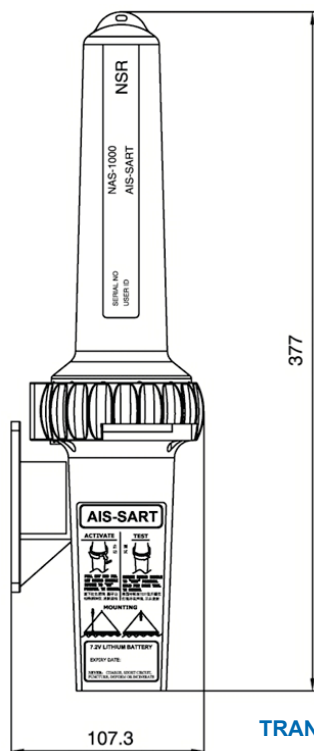

TRANSPONDER

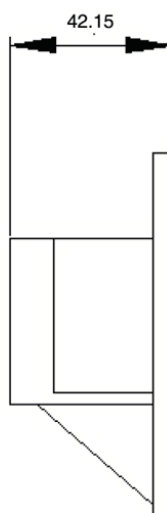

MOUNTING BRACKET

