



FEATURES

- **For wireless re-transmission of NMEA 0183 AIS data**
- **Connects with Tablets, Smartphones, WiFi enabled Chartplotters etc.**
- **Ideal for AIS monitoring at various stations on a small vessel**
- **Up to 3 WiFi connections and 5 TCP connections**
- **Use two i320W units to create a bidirectional NMEA over WiFi bridge**
- **Comprehensive 802.11b/g/n network capability**
- **WiFi Client mode allows connecting to existing WIFI networks**
- **Quick to configure and easy to install**
- **Two NMEA 0183 inputs with built in multiplexer. One NMEA 0183 output**
- **Configurable Baud Rate**
- **Supports TCP and UDP protocol in Server or Client Mode**
- **Built-in USB port for local monitoring**
- **Rugged Aluminium Housing**

INTERFACES

i320W BIDIRECTIONAL NMEA WIFI INTERFACE

SKU: 001-1061

[View Online >](#)

OVERVIEW

The i320W Bidirectional NMEA WiFi Interface is an upgraded version of the i300W. It provides a low cost method of setting up a wireless network on-board (802.11b/g/n), enabling you to stream your boat's NMEA 0183 electronic data, such as AIS data, position, depth, wind, compass heading to your tablet, smartphone, PC, or WiFi enabled chart-plotter.

Simple to set up, the i320W has 2 NMEA inputs which are multiplexed to a single high speed data output which transmits NMEA 0183 data over WiFi and provides communication with any suitable NMEA devices. With 2 inputs, it can accept NMEA 0183 data at 4800 from any GPS, Chartplotter or other navigation instruments or 38,400 baud input from any AIS receiver or transponder, so you only need one unit to collect and transmit all the navigation data of your boat via the wireless gateway.

For a vessel with a Chartplotter at the nav station, using the Comar i320W NMEA to WiFi interface, the helmsman can view all the navigation data on deck via a suitable device, and for boats with the Chartplotter at the helm, it's possible to check all the critical navigation data down below, making your boat's data truly portable.

Compatible with all major charting applications, tested with: Navionics, Aqua Map, AFTrack, iSailor, NV Charts and OpenCPN.

APPLICATIONS

- A helmsman can view all the navigation data on deck via a suitable device such as a smartphone or tablet
- For boats with the Chartplotter at the helm, all the critical navigation data can be viewed from anywhere on the boat

RELATED PRODUCTS

[Comar Systems' range of AIS receivers](#)

[i300W](#) - NMEA to WiFi Interface

PHYSICAL	
Weight:	200g
Dimensions:	L 120 mm W 86 mm D 37 mm
Mounting:	To flat surface
Connections:	8-way Screw Terminals USB 2.0 Port: Type B Supplied: USB Cable
Construction:	Aluminium, ABS End Caps
Finish:	Black Fine Texture Paint, Grey ABS

OPERATIONAL	
Input:	Two NMEA 0183 inputs configurable to 4800, 9600, 19200, 38,400 Baud or auto baud selector
Output:	One NMEA 0183 output configurable to 4800, 9600, 19200, 38,400 Baud or auto baud selector
WIFI:	2.4 GHz 802.11b/g/n
Connections:	Up to 3 WiFi and 5 TCP connections. WiFi Client mode allows connecting to existing WiFi networks to use the existing Internet Connection simultaneously with the AIS data. Bidirectional NMEA data flow
Protocols:	TCP: Server or Client mode UDP: Server or Client mode

ELECTRICAL	
Power:	9-30 V DC
Current:	100 mA @ 12 V DC

ENVIRONMENTAL	
IP rating:	IP40
Operating temp:	-15°C to +55°C
Compass:	Safe Distance 50 cm

ADDITIONAL	
<ul style="list-style-type: none"> A suitable App or Program is required to display the data 	

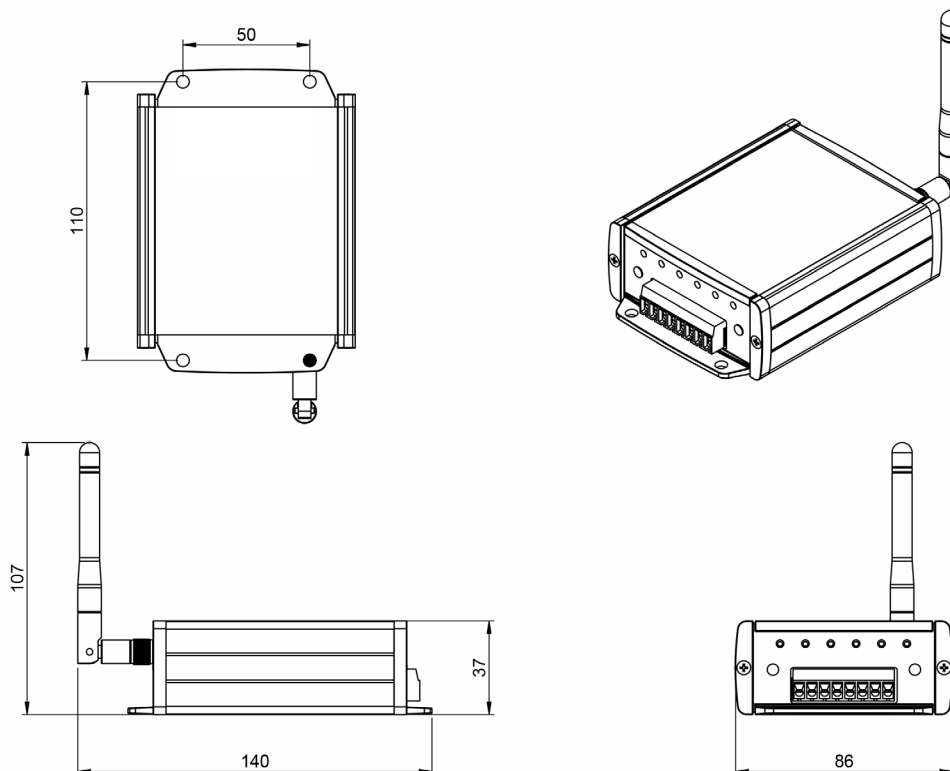

Agenzia
ufficiale per
l'Italia :



Telefono 010 870058 r.a.
Telefax 010 870248
e-mail: apelmar@koden.it
<http://www.koden.it>

Copyright © 2019 Comar Systems Ltd. - i320W Datasheet v06r02

Vittlefields Technology Centre, Forest Road, Newport, Isle of Wight, United Kingdom. PO304LY
Comar Systems Ltd. reserves the right to make changes to its products and specifications without prior notice.

